

Schottky Barrier Rectifier

Features

- Power pack
- Metal silicon junction ,majority carrier conduction
- Guard ring for overvoltage protection
- Low power loss ,high efficiency
- High current capability ,low forward voltage drop
- High forward surge capability
- High frequency operation
- Meets MSL Level 1, per J-STD-020, LF MAX peak of 245°C (for TO-263 package)
- Solder bath temperature 275°C maximum, 10s, per JESD22-B106 (for TO-220AB and ITO-220AB package)
- Component in accordance to RoHS 2011/65/EU

Mechanical Data

- Case: JEDEC TO-220AB, ITO-220AB, TO-263
- Molding compound meets UL94V-0 flammability rating
- Terminals: Lead solderable per J-STD-002 and JESD22-B102
- Polarity: As marked
- Mounting Torque: 10 in-lbs maximum

Typical Applications

For use in low voltage ,high frequency inverters ,DC/DC converters, free wheeling ,and polarity protection applications

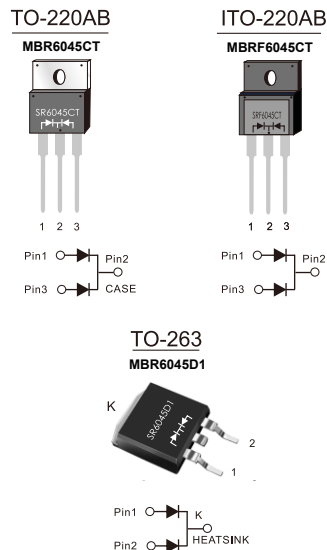

PRIMARY CHARACTERISTICS	
$I_{F(AV)}$	2×30A
V_{RRM}	45V
I_{FSM}	300A
VF at $I_F=30.0A$, Per leg	0.56V
I_r	100 μ A
$T_J(MAX)$	150°C
Package	TO-220AB, ITO-220AB, TO-263
Diode variations	Common cathode

Maximum Ratings ($T_a=25^\circ C$ Unless otherwise specified)

Parameter	Symbol	Value	Unit
Maximum repetitive peak reverse voltage	V_{RRM}	45	V
Maximum average forward rectified current (see fig.1)	Per leg	30.0	A
	Total device	60.0	
Peak forward surge current 8.3ms single half sine-wave superimposed on rated load (JEDEC method at rated TL)	I_{FSM}	300	A
Peak repetitive reverse current per diode at $t_p=2 \mu s$ 1KHz	I_{RRM}	0.5	A
Operating junction and Storage temperature range	T_J, T_{stg}	-55 to +150	°C
Isolation voltage (ITO-220AB only) from terminals to heatsink $t=1$ min	V_{AC}	1500	V

■Electrical Characteristics (T_a=25 °C Unless otherwise specified)

Parameter	Test Conditions		Symbol	TYP.	MAX.	Unit
Instantaneous forward voltage	Per leg I _F =30.0A	T _A =25°C	V _F ¹⁾	0.56	0.60	V
		T _A =100°C		0.52	–	
		T _A =125°C		0.50	–	
	Per leg I _F =10.0A	T _A =25°C		0.40	–	
		T _A =100°C		0.36	–	
		T _A =125°C		0.35	–	
Reverse current	V _R =45V	T _A =25°C	I _R ²⁾	100	200	μA
		T _A =100°C		8	15	mA
		T _A =125°C		20	50	
Typical junction capacitance	4V, 1MHz		C _J	930		pF

Notes: 1.Pulse test: 300 μs pulse width, 1% duty cycle

2.Pulse test: pulse width ≤ 40ms

■Thermal Characteristics

Parameter	Symbol	TO-220AB	ITO-220AB	TO-263	Unit
Typical thermal resistance ³⁾	R _{θJC}	2.5	4.5	2.5	°C/W

3.Thermal resistance from junction to case

■Available Pack Information

Product code	Pack	Box Size L×W×H(mm)	Quantity (pcs/box)	Carton Size L×W×H(mm)	Quantity (box/carton)
SR6045CT-TO-220AB	P/T	558×148×38	1000	565×225×170	5
SRF6045CT-ITO-220AB	P/T	558×148×38	1000	565×225×170	5
SR6045D1-TO-263	P/T	558×148×38	1000	565×225×170	5

■ Characteristics (Typical)

FIG.1-FORWARD CURRENT DERATING CURVE

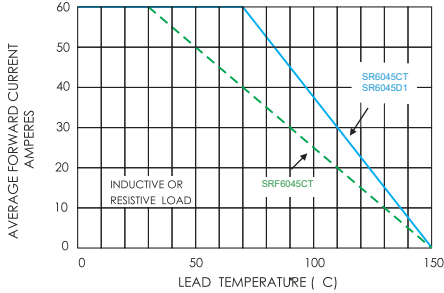

FIG.2-MAXIMUM NON-REPETITIVE PEAK FORWARD SURGE CURRENT

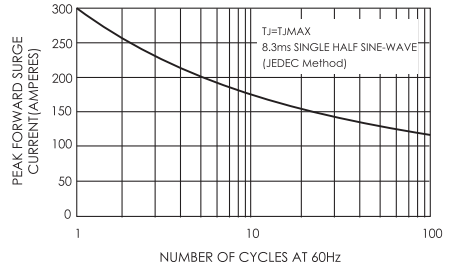

FIG.3-TYPICAL INSTANTANEOUS FORWARD CHARACTERISTICS

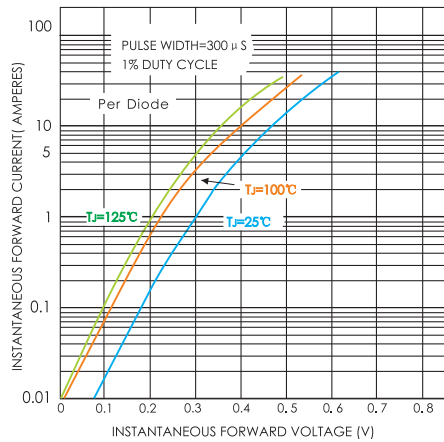

FIG.4-TYPICAL REVERSE CHARACTERISTICS

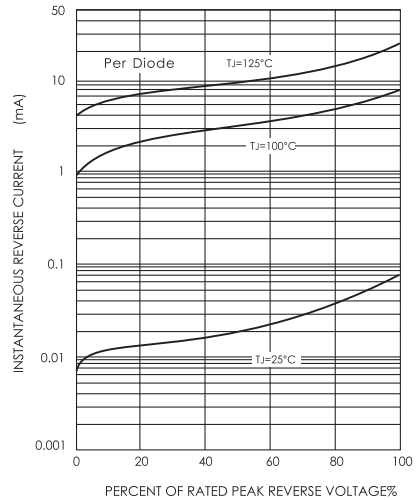
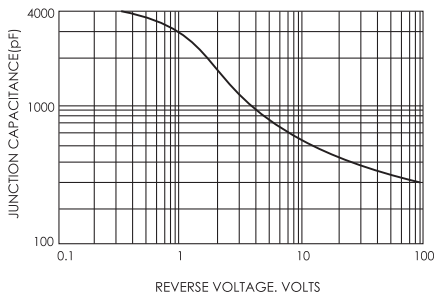
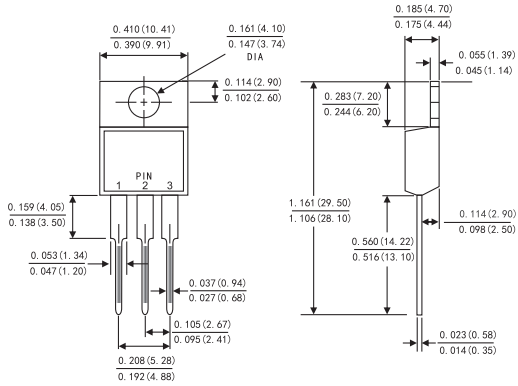

FIG.5-TYPICAL JUNCTION CAPACITANCE



■ Outline Dimensions

TO-220AB



ITO-220AB

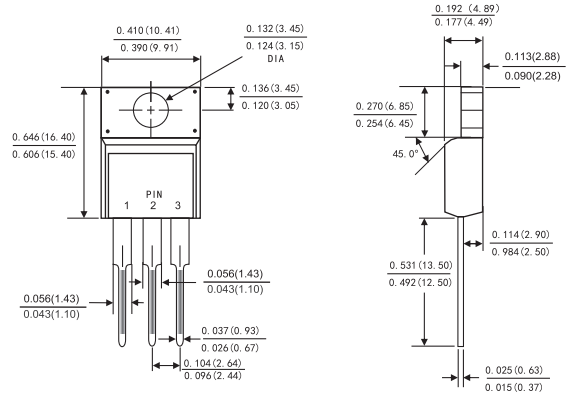

TO-263

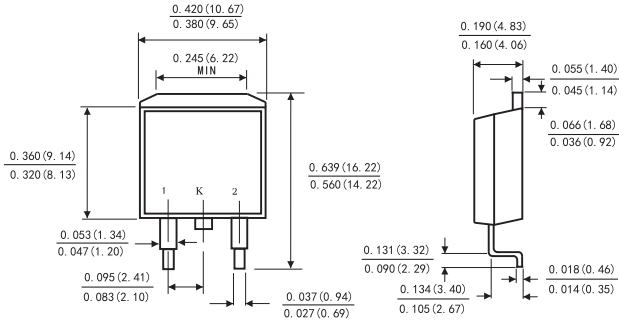

Suggested Pad Layout

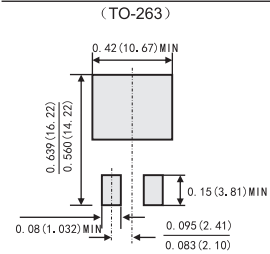

Dimensions in inches and (millimeters)